

# PREDICTION OF PATIENTS' ILLNESS BASED ON AVERAGE TEMPERATURE AND RAINFALL IN AZ-ZAINIYAH CLINIC USING BACKPROPAGATION METHOD

*by M. Noer Fadli Hidayat, M.kom*

---

**Submission date:** 09-Jan-2022 02:06AM (UTC+0000)

**Submission ID:** 1738965729

**File name:** Jurnal\_Penelitian\_Cak\_Pank.docx (2.91M)

**Word count:** 6149

**Character count:** 34842

ISSN: 2774-4574 ; E-ISSN: 2774-4574  
TRILOGI, 2(1), Januari-April 2021 (35-52)  
@2020 Lembaga Penerbitan, Penelitian,  
dan Pengabdian kepada Masyarakat (LP3M)  
Universitas Nurul Jadid Paiton Probolinggo  
DOI: <https://doi.org/>

JURNAL  
**TRILOGI**  
Ilmu Teknologi, Kesehatan, dan Humaniora

## **PREDICTION OF PATIENTS' ILLNESS BASED ON AVERAGE TEMPERATURE AND RAINFALL IN AZ- ZAINIYAH CLINIC USING BACKPROPAGATION METHOD**

**M Noer Fadli Hidayat**

Universitas Nurul Jadid, Probolinggo

[fadli@unuja.ac.id](mailto:fadli@unuja.ac.id)

### **Abstract**

### **Keywords:**

### **Abstrak**

The purpose of this study is to predict the type of disease in students based on the average temperature and rainfall at the Az-Zainiyah clinic using the backpropagation method. With this research, we hope that the prediction/estimation process on the type of patient's disease using the backpropagation artificial neural network method provides a solution with precise and accurate prediction results based on data on many patients, average temperature, and previous rainfall. This research is carried out through a process of predicting the type of disease by collecting time-series data from patient visit reports. The raw data obtained are examined for completeness and quality of the data. Then, the data was analyzed and applied to an artificial neural network method to predict the type of patient's disease based on many patients, average temperature, and rainfall. Furthermore, the artificial neural network will be optimized by the backpropagation algorithm. From this study, we find that the percentage of precision obtained in the experimental type of pharyngitis/sore throat disease in November 2020 with an average precision percentage is 68.92%, the best precision percentage is 90.25%, and the worst precision percentage 47.59%. In December 2020, the average precision percentage is 41.46%, with the best precision percentage being 65.55%, and the worst precision percentage 4.92%. In the type of dermatitis/itching disease in November 2020, the best precision percentage is 98.81%, the average precision percentage is 68.31%, and the worst precision percentage is -21.57 %. For December 2020, the average precision percentage is -63.27%, the best precision percentage is 48.37%, and the worst precision percentage is -183.85%.

**Katakunci:** prediction; disease; backpropagation;

## 1 Pendahuluan

The Disease can be interpreted as a condition when there is a disturbance in the form or function of one part of the body that causes the body to be unable to work normally<sup>32</sup> (Basariyadi, 2017). Climate change can also have direct<sup>24</sup> indirect effects on human health. The direct effects on human health are the effects of extreme cold and extreme heat (Ernyasih et al., 2018). High temperature accompanied by low humidity causes the body to easily dehydrate. Indirect effects are related to infectious diseases which are caused by air pollution and erratic weather (Surakusumah, 2011).

The human body is very susceptible to various types of diseases, both mild and chronic diseases. Unhealthy lifestyles and unfavorable environmental factors cause immunity decreasing which results in the outbreak of a disease. Environmental factors are all external factors affecting an individual who can be the form of social environment, biological environment, and physical environment. One of the physical environments, namely climate, needs to be watched out for because disease transmission will increase with climate change (Bustan, 1997). Part of the physical environmental conditions is air humidity and rainfall, one of the elements that affect the climate is rainfall (Paramita and Mukono, 2018).

In Nurul Jadid Islamic Boarding School, the student health service is carried out by Azzainiyah Clinic. It also provides health counseling services, health consulting services, medical services, and other health services. Azzainiyah is a health clinic founded by the Nurul Jadid Islamic Boarding School located in Tanjung Lor Hamlet, Karanganyar, Paiton, Probolinggo Regency. In addition to providing health services to students, this clinic is also a social institution that accommodates pesantren services in the social and community fields. Az-Zainiyah Clinic is for students, teachers, lecturers, employees, and the general public around them.

In carrying out health services, the provision of medicines is not based on the number of patients suffering from a type of disease whose grade may increase in the coming months yet, which is influenced by several factors, namely average temperature and rainfall. Thus, resulting in minimal drug stock availability, not under the needs based on the type of patient's illness, and even empty drug stocks. It will be a big problem

for general patients and students in the Nurul<sup>1</sup> did area. Therefore, we need a method or method to predict the type of patient's disease based on the number of patients, the average temperature, and rainfall by looking at the previous data. One way to predict is to use an artificial neural network.

An artificial Neural Network (ANN) is a simulated representation of the human brain which always tries to simulate the learning process in the human brain. The term artificial here is used because this neural network is implemented using a computer program that can complete several calculation processes during the learning process (Kusumadewi, 2003). The main advantage of the ANN system is the ability to "learn" from the examples given. Backpropagation is a supervised learning algorithm and is usually used by multi-layer perceptrons to change the weights connected to neurons in the hidden layer. Backpropagation is a type of controlled training (supervised) that uses a weight adjustment pattern to achieve a minimum error value between the predicted output and the exact output . (F.<sup>34</sup>handi, 2009).

The artificial neural network is a branch of AI (Artificial Intelligence), which is a simulated representation of the human brain that always tries to simulate the learning process in the human brain. This artificial term is implemented using a computer program that can complete some calculation processes during the learning process (Suyanto, 2011). The<sup>15</sup> backpropagation method is one of the methods used in learning from artificial neural network algorithms (Patel, 2013). The backpropagation method has a high level of accuracy because the training process is carried out repeatedly, so it produces a value that has a very small error (Anshari and Muniar, 2016). The backpropagation learning method is applied widely for solving a problem related to identification, prediction, and pattern recognition.

We can use the backpropagation method in medical analysis, such as identifying a disease having symptoms biased between one type and another. It has been proved in the journal "Application of artificial neural networks to predict respiratory tract diseases<sup>1</sup> with the backpropagation method" by Novi Indah Pradasari, F.Trias Pontia W, and Dedi Triyanto (2013). In their journal, they used the backpropagation method to predict respiratory tract diseases based on disease symptoms

arranged into 12 input variables. The system's output target is in the form of respiratory tract diseases identified by the system. The system has disease limits that can be identified. Those are Asthma, ARI, Pneumonia, Bronchitis, Sinusitis, and Tuberculosis. This study concluded that we could use the backpropagation method to predict respiratory tract disease with an accuracy of 91.66% obtained from training 96 data and testing 24 data using two hidden layers, a target error of 0.0001, and a learning rate of 0.1.

Miss Ankeeta R. Patel and Maulin M. Joshi (2013) conducted research using backpropagation to diagnose heart disease using data from Cleveland. The results of the tests carried out with Cleveland data obtained MSE 0.0013 and the success reached 100%. So this study shows that neural networks are quite good for use in the diagnosis of heart disease. In another study, the backpropagation method was also used to predict heart disease. The result of this research is that the backpropagation algorithm can predict heart disease with more accurate results, namely 91.45% accuracy (Rifai, 2013).

Furthermore, the research conducted by Dewi & Muslikh (2013) was about comparing the accuracy of backpropagation neural networks with the Adaptive Neuro-Fuzzy Inference System (ANFIS) for predicting the weather. In backpropagation, there are 3 layers and in the hidden layer, the number of hidden neurons can be changed so that an optimal network can be generated. However, in ANFIS there are 5 layers at the initial stage using the K-Mean Clustering method to produce premise and consequent parameters that are useful during learning. From the results of the tests carried out, it was found that the backpropagation method obtained a smaller Root Mean Square Error (RMSE) value and greater accuracy than the ANFIS method.

According to the description and the research conducted, the backpropagation method can be used as a support for predicting the type of patient's disease based on the number of patients, average temperature, and rainfall at the Az-Zainiyah clinic.

Based on this description, the purpose of this study is to predict the type of disease in students based on the average temperature and rainfall at the Az-Zainiyah clinic using the backpropagation method. With this research, we expect that the prediction/estimation process on the type of patient's disease using the backpropagation artificial neural network method provides a solution with precise and accurate prediction

results based on the number of patients, average temperature, and previous rainfall.

## 2 Metode

To achieve the expected goals in this study, we make a research design in the process of predicting the type of patient's disease based on data on the number of patients, average temperature, and rainfall at the Az-Zainiyah Clinic, which we can see in the following figure.



The steps carried out according to the research design based on Figure 3.1 to predict the type of patient's disease at the Azziniyah Clinic using the backpropagation method we can explain in more detail as follows.

### 1. Data Collecting

We collect Data through an observation process at the Azzainiyah Clinic. The activities carried out in this observation are collecting time-series data on patient visit reports, such as a list of names and the highest total number of diseases every week. We also record steps from weekly frequency data to monthly frequency data. The data used in this study is data on the type of patient's disease. Those are pharyngitis/sore throat and dermatitis/itching from January 2020 until December 2020.

### 2. Preprocessing Data

At this stage, we combine and check the raw data obtained for the completeness and quality of the data. We check whether the data is ready and can be used to develop models and make forecasts/predictions using the data. Furthermore, we will correct the data if there is empty data or noise. We can improve the data using old data or forecasting empty data in advance using the moving average method or averaging the previous data. Thus, we can say the data is valid for making models and forecasting.

Then, we process the data according to research needs. This data is categorized to facilitate the process of testing the method. After it is ready to use, the next step is developing an artificial neural network (ANN) model. The development of this ANN model can be started by categorizing the parameters into inputs and outputs. We classify the input data based on predetermined parameters, these are the number of patients last month, the average temperature

last month, the average temperature next month, last month's rainfall, and rainfall next month. Then these parameters produce an output variable, namely the target of "many patients next month". We use all of those parameters as input for the training and testing process which will result in the precision value of the model and the optimization that will be applied. At this stage, the data obtained from the results of data collection is 80% for training and 20% for testing.

Furthermore, the value of the input variable from each of the testing and training data is normalized. We normalize the data to adjust the value of the data to the range of activation functions used in the network. The process of the data normalizing is done automatically by using the toolbox in MATLAB, that is mapstd. So that values that already have a fixed range can be used in the next stage.

### 3. Backpropagation Implementation

At the implementation stage, the analyzed data are grouped based on which variables are related to. After we analyze the data, we then applied to the proposed method, namely the artificial neural network method to predict the type of patient's disease based on the number of patients, the average temperature, and rainfall. Furthermore, the artificial neural network will be optimized with the backpropagation algorithm and implemented in MATLAB.

Next, we determine the backpropagation architecture consisting of the input, hidden, and output layer as well as the parameters used in the model training process consisting of the learning rate, momentum, maximum epoch, and activation function. The input layer contains five units representing parameters. There are 3 layers for last month and 2 layers for next month. The layers for last month are the number of patients, average temperature, and rainfall. For another month, the layers are average temperature and rainfall. The output layer consists of one unit which will result in "many patients next month".

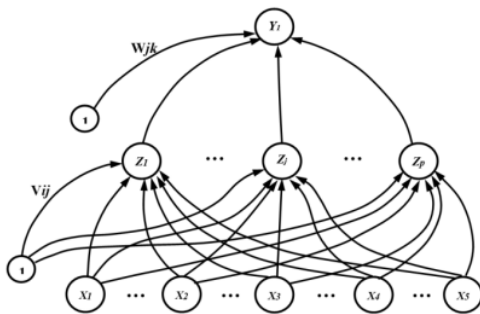

Gambar 1 : Arsitektur Jaringan Backpropagation

### 4. Result Testing

Testing the prediction results is the most critical stage in this research. At this stage, we verify the proposed model to see the results in the form of rules that will be used in decision support, to find out and determine whether a backpropagation neural network method has been successfully developed or not. Then evaluate and validate the results to determine the level of precision of the model. We test the preciseness of data testing using the following formula.

$$100\% - \left[ \frac{| \text{Data Aktual (Target)} - \text{Hasil Peramalan (Prediksi)} |}{\text{Data Aktual (Target)}} \right] \times 100\%$$

### 5. Analysis and Conclusion

From the test results, we can draw the analysis and conclusions about the level of precision of the backpropagation artificial neural network (ANN) method in predicting the type of patient's disease based on the number of patients, average temperature, and rainfall at the Az-Zainiyah clinic.

## 3 Discussion

### 3.1. Disease

The disease is the failure of the adaptation process of a living being to react appropriately to stimuli or pressures so that disturbances in the function or morphology of organs or body systems appear (Basariyadi, 2017).

### 3.2. Air Temperature and Rainfall

Air temperature is the level or degree of heat from the activity of molecules in the atmosphere expressed on the Celsius scale. The air temperature of each area is different. It is influenced by several factors, namely the angle of incidence of sunlight, the altitude of the place, wind and ocean currents, duration of irradiation, and clouds (Wulandari, 2011). Usually, the measurement of temperature or air temperature is expressed in Celsius (C), Reaumur (R), and Fahrenheit (F) scales. The air temperature in the open environment is not the same as the air in the building, neither is the ambient temperature such as in the dry and the wet fields. Measurement of air temperature only obtains one value which states the average value of the atmosphere. There

are two environmental air temperature measurement scales that are often used, namely the Fahrenheit scale used in the UK and the Celsius scale used by most countries in the world (Heriyani, 2019). In general, the maximum temperature occurs afternoon, usually between 12.00 to 14.00 and the minimum temperature occurs at 06.00 local times and around sunrise (Tjasyono, 2004).

Average daily air temperature is defined as the average of observations for 4 hours (one day) conducted every hour. The average daily air temperature can be calculated by adding up the maximum and minimum temperatures and then dividing by two. The average monthly temperature is the sum of the daily temperatures in a month divided by the number of days in that month (Tjasyono, 2004).

Rainfall is the height of rainwater that collects in a flat place, does not evaporate, does not seep, and does not flow. Rainfall of 1 (one) millimeter means that in an area of one square meter on a flat place, one millimeter of water can be accommodated or one liter of water can be accommodated within a certain period (Darmaga Climatology Station Bogor, 2012). Rainfall that falls in the territory of Indonesia is influenced by factors such as the shape of the terrain or topography, the direction of the terrain, the direction of the wind parallel to the coastline, and the distance the wind travels over flat terrain (Regariana, 2005).

### 3.3. Backpropagation

Backpropagation is one of the learning algorithms used for networks with multilayer networks or networks of many layers to change the weights connected to the neurons in the hidden layer. In the backpropagation method, there are two calculation paths. Those are forward propagation and backward propagation (Wadi, 2020). This network model is often used for the process of prediction, recognition, and forecasting (Dewi & Musliikh, 2013).

In a backpropagation network, each unit in the input layer corresponds to every unit in the hidden layer. Each unit in the hidden layer is related to the unit in the output layer. This network consists of many layers (multilayer network). When this network is given an input pattern as a training pattern, then the pattern goes to the hidden layer units to be further forwarded to the units in the output layer. Then the output layer units will respond as the output of the artificial neural network. When

the output is not as expected, the output will be propagated backward in the hidden layer and then from the hidden layer to the input layer.

There are three (3) basic backpropagation training algorithms, namely: backpropagation architecture, backpropagation activation function, and backpropagation basic training.

#### 1. Backpropagation Architecture

The backpropagation network consists of several layers, those are an input layer with n neurons (plus a bias), a hidden layer consists of p neurons (plus a bias), and m outputs where each neuron in a layer is fully connected to each. Neurons in the layer above or below it, except in the bias, are only fully connected to the neurons of the layer above (Fausett, 1994).

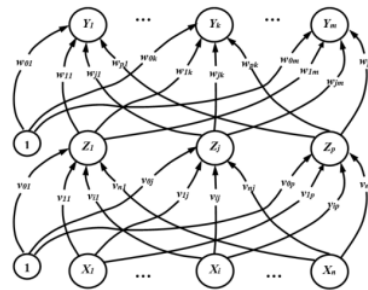

Gambar 2: Arsitektur Backpropagation

#### 2. Function of Backpropagation Activation

- a. The binary sigmoid function is an activation function that is often used in backpropagation activation whose range is (0, 1).

$$f_1(x) = \frac{1}{1+e^{-x}} \text{ dengan turunan } f_{1'}(x) = f_1(x)[1 - f_1(x)] \quad (2.1)$$

We illustrate the binary sigmoid function in the following figure.

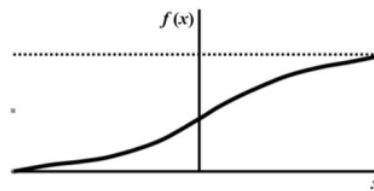

Gambar 3 : Binary Sigmoid Function

- b. The bipolar binary sigmoid function is a function whose form is similar to the binary sigmoid function, but with a range (-1, 1).

$$f_2(x) = \frac{2}{1+e^{-x}} - 1 \text{ with the derivative } f_{2'}(x) = \frac{1}{2} [1 - f_2(x)][1 + f_2(x)] \quad (2.2)$$

The bipolar binary sigmoid function can be seen in the following figure.

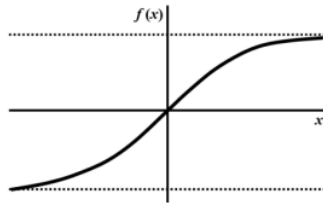

Gambar 4 : Bipolar Binary Sigmoid Function

### 3. Backpropagation Training

One of the activation functions defined in the previous section can be used in a given standard backpropagation algorithm. The shape of the data (especially the target value) is a critical factor in selecting the appropriate function. Another suitable activation function considered in Figure 2.4 is the binary sigmoid function. Note that due to the simple relationship between the value of the function and its derivative, no additional evaluation of the exponential is required to calculate the derivative required during the backpropagation phase of the algorithm (Fausett, 1994).

In the backpropagation training algorithm, there are three stages. The first stage is the feedforward propagation stage, namely, with the network calculates the output data, the second stage is the backward propagation stage (backpropagation) if there is an error (difference between the desired output target and the output value obtained), and the third stage is weight modification to reduce network-generated errors.

The backpropagation training algorithm is as follows:

Step 0: Initialize all weights with small random numbers.

Step 1: If the termination condition does not hold, perform steps 2-9.

Step 2: For each pair of training data, perform steps 3-8.

#### 1<sup>st</sup> Stage: Feedforward Propagation.

Step 3: Each input layer ( $X_i, i = 1, \dots, n$ ) receives the input signal  $x_i$  and forwards it to the hidden layer.

Step 4: Count all outputs in the hidden layer ( $Z_j, j = 1, \dots, p$ ),

$$z_{in_j} = v_{0j} + \sum_{i=1}^n x_i v_{ij} \quad (2.3)$$

Apply the activation function to calculate the output signal,

$$z_j = f(z_{in_j}) \quad (2.4)$$

and the signal to all output layer.

Step 5: Calculate all output in output layer ( $Y_k, k = 1, \dots, m$ ),

$$y_{in_k} = w_{0k} + \sum_{j=1}^p z_j w_{jk} \quad (2.5)$$

Apply the activation function to calculate the output signal,

$$Y_k = f(y_{in_k}) \quad (2.6)$$

#### 2<sup>nd</sup> Stage: BACKPROPAGATION

Step 6: Calculate the factor  $\delta$  on the output layer based on error in every output layer ( $Y_k, k = 1, \dots, m$ ),

$$\delta_k = (t_k - y_k) f'(y_{in_k}) \quad (2.7)$$

$\delta_k$  is the error unit which can be used in the change of layer weight below (step 7).

Calculate the unit of weight change  $w_{jk}$  (which will be used for changing the weight  $w_{jk}$ ) with the acceleration rate  $\alpha$ ,

$$\Delta w_{jk} = \alpha \delta_k z_j \quad (2.8)$$

Calculate the bias change (which will be used for change the weight  $w_{0k}$ ),

$$\Delta w_{0k} = \alpha \delta_k \quad (2.9)$$

and  $\delta_k$  to the layer below it.

Step 7: Calculate the factor  $\delta$  on the hidden layer based on the error in every hidden layer unit ( $Z_j, j = 1, \dots, p$ ),

$$\delta_{in_j} = \sum_{k=1}^m \delta_k w_{jk} \quad (2.10)$$

The factor  $\delta$  hidden layer is:

$$\delta_j = \delta_{in_j} f'(z_{in_j}) \quad (2.11)$$

Compute the weight change  $v_{ij}$  (which will be used for change the weight  $v_{ij}$  later),

$$\Delta v_{ij} = \alpha \delta_j x_i \quad (2.12)$$

#### 3<sup>rd</sup> Stage: Weight Change.

Step 8: Calculate all weight change.

The change of line weight which leads to the output layer,

$$w_{jk} (\text{baru}) = w_{jk} (\text{lama}) + \Delta w_{jk}, \quad (Y_k, k = 1, \dots, m; j = 0, \dots, p) \quad (2.13)$$

The change of line weight which leads to hidden layer,

$$v_{ij} (\text{baru}) = v_{ij} (\text{lama}) + \Delta v_{ij} \quad (Z_j, j = 1, \dots, p; i = 0, \dots, n) \quad (2.14)$$

Step 9: The training process is finished.

After the training is complete, the network can be used for pattern recognition. In this case, only forward propagation (steps 4 and 5) is to determine the network output.

### 3.4. Data Presentation

The results of data collection are conducted at the Az-Zainiyah clinic and the Meteorology,

Climatology and Geophysics Agency (BMKG) Malang Climatology Station. In the observations, researchers obtained time series data on patient visit reports from January to December 2020. In the reports obtained, there are five lists of the most common types of the disease every week. Then the researcher unites and groups the weekly frequency data into monthly frequency data based on which variables are related to each other. From the monthly data that has been put together and grouped, there are various types of diseases got. We only take two types of diseases that we use as parameters in the study as needed, namely pharyngitis/sore throat, and dermatitis/itching.

In the results from BMKG Malang Climatology Station, we get time-series data for daily climate reports. Then, from the daily frequency data, we process it into monthly frequency data by calculating the average results from the daily frequency data. The data needed by researchers are the parameter of the average temperature and rainfall. The results of data collection can be seen in Table 1.

Table 1: Data on Number of Patients, Average Temperature, and Rainfall from January to December 2020

Bulan-Tahun	Faringitis (Radang Tenggorokan)	Dermatitis (Gatal-Gatal)	Temperatur rata-rata (°C)	Curah hujan (mm)
Januari 2020	70	39	23,8	310,9
Februari 2020	25	40	23,7	642,9
Maret 2020	69	69	24,0	619,8
April 2020	66	21	24,8	595,2
Mei 2020	34	35	24,1	0,6
Juni 2020	21	2	23,2	1,9
Juli 2020	47	42	21,9	0,3
Agustus 2020	24	59	22,2	0,0
September 2020	55	52	23,8	0,1
Oktober 2020	29	21	25,2	0,2
November 2020	37	27	25,0	1196,1
Desember 2020	26	19	24,1	309,8

### 3.5. Data Preprocessing

The data obtained is then processed according to research needs. This data is categorized to facilitate the process of testing the backpropagation neural network (ANN) method to predict the type of patient's disease based on the number of patients, average temperature, and rainfall. The data in Table 4.1 are grouped based on which parameters are related. The parameters are the number of patients last month (pharyngitis/sore throat, and dermatitis/itching), the average temperature last month, the average temperature next month, rainfall last month, rainfall next month. These parameters become input variables which are described as follows.

$x_1$  = The number of Last Month's Patients (Pharyngitis/Sore Throat, and Dermatitis/Itching)

$x_2$  = Last Month's Average Temperature  
 $x_3$  = Next Month's Average Temperature  
 $x_4$  = Last Month's Rainfall  
 $x_5$  = Next Month's Rainfall

Next, the parameters deliver the following output variable or targets.

$t_1$  = The Number of Patients Next Month (Pharyngitis/Sore Throat, and Dermatitis/Itching).

We use all of these parameters as input for the training and testing process. Next, determine the dataset that we will use for 80% training data and 20% testing data.

Table 2 below shows the datasets preprocessed or grouped based on the parameters that we determined in the study.

Table 2 Grouping Results Based on Input and Output Parameters

Penyakit	Banyak Pasien	Temperatur Rata-Rata			Curah Hujan		Target Penyakit
		Bulan Kemarin (Januari 2020)	Bulan Kemarin (Januari 2020)	Bulan Depan (Februari 2020)	Bulan Kemarin (Januari 2020)	Bulan Depan (Februari 2020)	
Faringitis	70	23,8	23,7	310,9	642,9	25	
Dermatitis	39	23,8	23,7	310,9	642,9	40	

Furthermore, the value of the input variable is normalized automatically by using the toolbox in MATLAB, namely mapstd. So that values that already have a fixed range can be used in the next stage. All training data and testing data will be normalized using the standard deviation. Normalization is applied so that the values generated from the previous process are uniform. The following is an implementation in MATLAB through the coding process.

[Hasil\_normalisasi, ps] = mapstd (data\_input);

Sample data before normalization is shown in Table 3. Table 4 shows the results of the normalization of training data in Table 3, while testing data before and after normalization is shown in Table 5.

Table 3 Training Data Before Normalization Against Pharyngitis In January to October 2020

Banyak Pasien	Temperatur Rata-Rata			Curah Hujan	
	Bulan Kemarin	Bulan Kemarin	Bulan Depan	Bulan Kemarin	Bulan Depan
70	23,8	23,7	310,9	642,9	642,9
25	23,7	24,0	642,9	619,8	619,8
69	24,0	24,8	619,8	595,2	595,2
66	24,8	24,1	595,2	0,6	0,6
34	24,1	23,2	0,6	1,9	1,9
21	23,2	21,9	1,9	0,3	0,3
47	21,9	22,2	0,3	0,0	0,0
24	22,2	23,8	0,0	0,1	0,1
55	23,8	25,2	0,1	0,2	0,2

Table 4 Results of Training Data After Normalization of Pharyngitis Disease in January to October 2020



Banyak Pasien	Temperatur Rata-Rata			Curah Hujan	
	Bulan Kemarin	Bulan Kemarin	Bulan Depan	Bulan Kemarin	Bulan Depan
-0.5390	-0.7117	-0.7121	0.3611	1.6017	
-0.7278	-0.7317	-0.7307	1.1298	1.0604	
-0.6335	-0.7776	-0.7752	1.1326	1.0537	
-0.2994	-0.4614	-0.4640	1.7812	-0.5565	
1.1658	0.4990	0.4331	-1.0917	-1.0062	
0.6382	0.8259	0.7195	-1.0245	-1.1591	
1.4780	0.1879	0.1997	-0.9246	-0.9411	
0.7830	0.6391	0.7655	-1.0981	-1.0894	
1.5087	0.1293	0.1901	-0.9163	-0.9118	

Table 5 Testing Data Before and After Normalization of Pharyngitis Disease in November 2020

Data Sebelum Normalisasi					
Banyak Pasien	Temperatur Rata-Rata			Curah Hujan	
	Bulan Kemarin	Bulan Kemarin	Bulan Depan	Bulan Kemarin	Bulan Depan
29	25.2	0.2	1196.1		
Data Sesudah Normalisasi					
Banyak Pasien	Temperatur Rata-Rata			Curah Hujan	
	Bulan Kemarin	Bulan Kemarin	Bulan Depan	Bulan Kemarin	Bulan Depan
-0.4297	-0.4370	-0.4373	-0.4844	1.7884	

### 3.6. Implementation on Backpropagation

At the implementation stage of the method based on the research design in the previous chapter, after normalizing the input data is to create a network that we use in the training process. Next, determine the backpropagation architecture to get an artificial neural network (ANN) model with good performance in forecasting/predicting. In this study, the backpropagation architecture used is 5-13-1 with 5 (five) parameters as variables that become signals as inputs, 13 (thirteen) hidden layers, and 1 (one) parameter that produces output signal variables. (output) can be seen in Figure 4.1.

The next is to determine and assign values to the parameters that affect the model training process. The parameters used to consist of the learning rate (lr), momentum (mc), maximum iteration, and activation function which uses the logsig activation function in the first layer and the second function is linear (purelin) and the activation function used in the training process uses *traingdx*, which combines learning rate or learning rate (lr) and momentum (mc) during the training process. It can be seen in the syntax used to build the ANN and the parameters that affect it.

```

8
% Pembuatan JST
net = newff(minmax(data_latih), [13 1], {'logsig', 'purelin'}, 'traingdx');
    
```

```

% Memberikan nilai untuk mempengaruhi proses
pelatihan
net.performFcn = 'mse';
net.trainParam.goal = 0.001;
net.trainParam.show = 20;
net.trainParam.epochs = 1000;
net.trainParam.mc = 0.95;
net.trainParam.lr = 0.1;
    
```

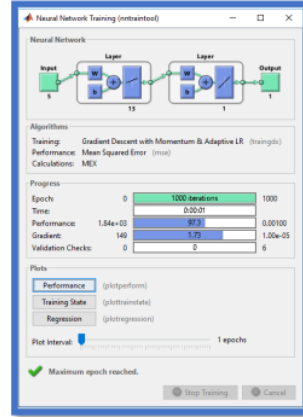

Figure 5 Implementation of Backpropagation Architecture

The results of the backpropagation implementation tested to predict the type of patient's disease, such as taking an example of pharyngitis based on many patients, average temperature, and rainfall illustrated in graphical form can be seen in Figure 4.4. This graph shows the target and predicted ANN results from the backpropagation architecture formed and implemented into the MATLAB R2014a application. This graph is generated in Figures 6 and 7 which are tested during one trial to predict pharyngitis in November and December 2020. The target for pharyngitis in November 2020 was 37 people with a predicted result of 25.92, which can be seen in Figure 4.2, and the target in December 2020 is 26 people with a prediction result of 48.08 in Figure 7.

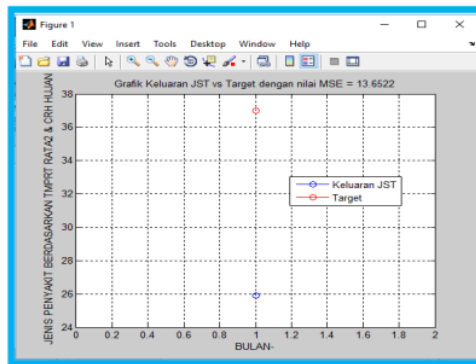

Figure 6 Example of Experimental Results Against Pharyngitis Disease in November 2020

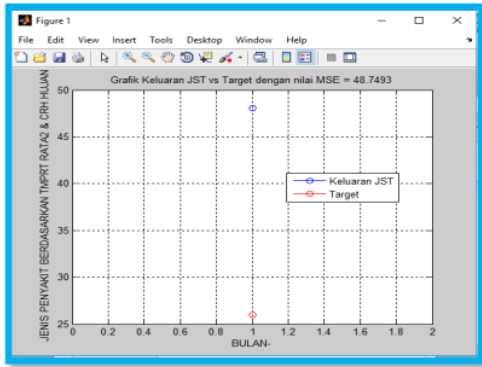

Figure 7 Example of Experimental Results Against Pharyngitis Disease in December 2020

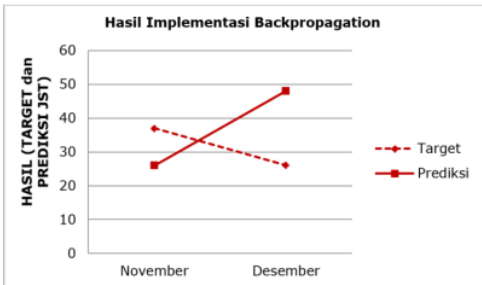

Figure 8 Results of Backpropagation Implementation

### 3.7. Test Results

In this study, we conduct 20 trials on each type of disease (pharyngitis/sore throat and dermatitis/itching) for November and December 2020. To find out how many patients had pharyngitis in November 2020, the training data used are from January to October 2020. Then to predict December 2020, the training data used is data from January to November 2020. This process is also carried out on dermatitis. The results of the trial of the type of pharyngitis/strep throat can be seen in Table 6 by including the target value (T), prediction (P) or output generated by the backpropagation artificial neural network, and the difference (S) from the comparison between the target value and the predicted value. To find the difference (S) is done by using calculations in Microsoft Excel, namely the absolute target value (T) minus the absolute prediction value (P). The results of the trial of the

type of dermatitis/itching disease can be seen in Table 7.

Table 6 Trial Results on Types of Pharyngitis/Throat Disease

Eksperimen ke-	November			Desember		
	T	P	S	T	P	S
1	37	25.9153	11.0847	26	48.0792	22.0792
2	37	24.1864	12.8136	26	34.9558	8.9558
3	37	27.1080	9.8920	26	39.2020	13.2020
4	37	28.2777	8.7223	26	39.5590	13.5590
5	37	23.7224	13.2776	26	37.3396	11.3396
6	37	23.2006	13.7994	26	42.9846	16.9846
7	37	22.7107	14.2893	26	40.0025	14.0025
8	37	25.2044	11.7956	26	39.4115	13.4115
9	37	29.2600	7.7400	26	38.6342	12.6342
10	37	25.4049	11.5951	26	35.7402	9.7402
11	37	33.3933	3.6067	26	42.0052	16.0052
12	37	22.6722	14.3278	26	48.5215	22.5215
13	37	23.6113	13.3887	26	35.0575	9.0575
14	37	17.6090	19.3910	26	44.2524	18.2524
15	37	26.0597	10.9403	26	35.5026	9.5026
16	37	30.6538	6.3462	26	50.7214	24.7214
17	37	25.1739	11.8261	26	36.2327	10.2327
18	37	20.1751	16.8249	26	37.7013	11.7013
19	37	32.1847	4.8153	26	49.6945	23.6945
20	37	23.4956	13.5044	26	48.7874	22.7874
<b>JUMLAH/RATA-RATA</b>	<b>37</b>	<b>25.5009</b>	<b>11.4991</b>	<b>26</b>	<b>41.2193</b>	<b>15.2193</b>

Table 7 Trial Results on Types of Dermatitis/Itching

Eksperimen ke-	November		Desember			
	T	S	T	S		
1	27	40.4389	13.4389	19	37.1607	18.1607
2	27	33.7563	6.7563	19	53.2159	34.2159
3	27	28.6609	1.6609	19	47.8314	28.8314
4	27	36.5785	9.5785	19	36.7628	17.7628
5	27	21.1410	5.8590	19	72.9316	53.9316
6	27	23.9257	3.0743	19	46.3367	27.3367
7	27	38.9218	11.9218	19	41.7236	22.7236
8	27	40.3179	13.3179	19	60.5680	41.5680
9	27	27.3211	0.3211	19	67.9235	48.9235
10	27	27.8142	0.8142	19	68.6259	49.6259
11	27	40.6239	13.6239	19	40.0439	21.0439
12	27	43.0088	16.0088	19	52.3529	33.3529
13	27	25.1436	1.8564	19	44.9660	25.9660
14	27	16.5981	10.4019	19	39.8997	20.8997
15	27	22.6818	4.3182	19	53.5556	34.5556
16	27	-5.8239	32.8239	19	57.1586	38.1586
17	27	38.0822	11.0822	19	46.0267	27.0267
18	27	27.9503	0.9503	19	28.8088	9.8088
19	27	23.0148	6.0148	19	53.7180	34.7180
20	27	34.3227	7.3227	19	50.8123	31.8123
<b>JUMLAH/RATA-RATA</b>	<b>27</b>	<b>29.7239</b>	<b>8.5573</b>	<b>19</b>	<b>50.0211</b>	<b>31.0211</b>

Then with the results of the 20 trials, the predicted output for each type of disease (pharyngitis/sore throat, and dermatitis/itching) every month (November and December 2020) is illustrated in Figure 9. This image is a graphic image including the target value and the average of the predicted results (ANN outputs) carried out for 20 trials for each type of disease. The target for pharyngitis in November 2020 is 37 people with an average prediction result of 25.50. While the target for pharyngitis in December 2020 was 26 people with an average prediction result of 41.22. Furthermore, the target for dermatitis in November 2020 are 27 people with an average prediction of 29.72, and for the target of dermatitis in December as many as 19 people with an average prediction of 50.02.

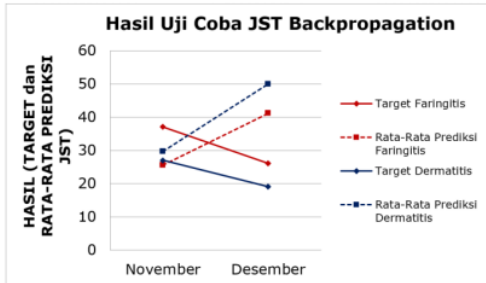

Figure 9 Average Trial Results Against Pharyngitis and Dermatitis Targets in November and December 2020

### 3.8. Analysis and Conclusion

After testing the model we make, we carry out the calculation of the percentage of precision. The precision percentage results are obtained from 20 trials on each type of disease every November and December 2020.

We divide the precision percentage results into 3 (three) conditions, namely the average precision percentage result, the best precision percentage result, and the worst precision percentage result from the 2nd (two) type of disease (pharyngitis / sore throat, dermatitis/hives). The best percentage results are marked with a red circle and the worst percentage results with a blue circle. To obtain the three conditions of precision percentage results, look at Table 6 and Table 7. Then the calculation is carried out using the 100% formula -  $\frac{[|Actual Data (Target) - Forecasting Results (Prediction)| : Actual Data (Target)] \times 100}{100}$ .

The results of the percentage of precision obtained in the pharyngitis/laryngitis type experiment in November 2020 with an average precision is percentage of 68.92%. The best percentage of precision is obtained in the 11th experiment with a precision percentage of 90.25% and the worst percentage of precision in the 14th experiment of 47.59% which is illustrated in graphical form in Figure 10.

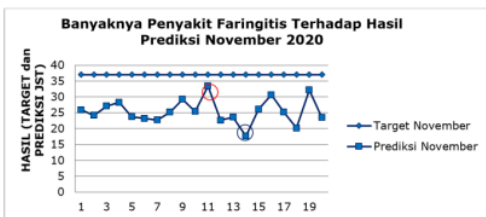

Figure 10 Pharyngitis Disease Trial Results in November 2020

In pharyngitis disease, in December 2020 the average precision percentage was 41.46%, with the best precision percentage of 65.55% obtained in the 2nd experiment, and the worst precision percentage of 4.92% obtained in the 16th experiment can be seen in Figure 11.

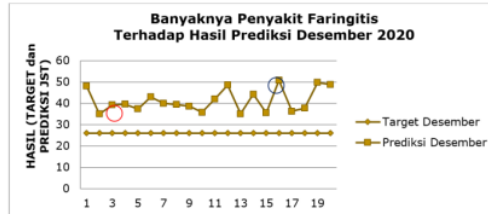

Figure 11 Pharyngitis Disease Trial Results in December 2020

Figure 12 is an image illustrated in graphic form for the type of Dermatitis/Itching in November 2020. The best percentage of precision is obtained in the 9th experiment with a precision percentage of 98.81%, the average precision percentage of 68.31%, and the worst precision percentage of -21,57% in the 16th experiment.

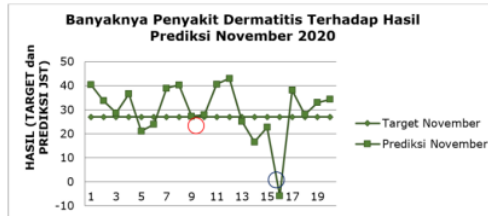

Figure 12 Dermatitis Disease Trial Results in November 2020

Dermatitis disease in December 2020 is illustrated in graphical form in Figure 13 with an average precision percentage of -63.27%. The best percentage of precision is obtained in the 18th experiment was 48.37% and the worst percentage of precision -183.85% was obtained in the second experiment 5.

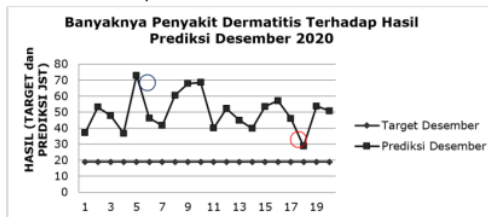

Figure 13 Trial Results of Dermatitis Disease in December 2020

By looking at the results of the trial of predicting the type of patient's disease based on the number of patients, the average temperature,

and rainfall at the Az-Zainiyah clinic, we can see that backpropagation can predict the patient's disease well. Some experiments get a poor percentage of precision because the prediction results of the artificial neural network (ANN) are too low or too large to exceed the actual data target, it will have a large error value. However, if the prediction results from the ANN output are close to the actual target data, it will produce a good percentage of precision. In addition, there are data inputs in the form of many patients, and rainfall in one month with the following month experiencing drastic changes so that affect the training data.

## 4 Closing

Based on the results of the research that has been carried out, we can conclude that the backpropagation Artificial Neural Network (ANN) method can be applied properly to predict the number of patients for a type of disease at the Az-Zainiyah clinic based on data on the number of patients, average temperature and previous rainfall. The backpropagation algorithm can predict through several stages, namely, entering data on the number of patients for a disease (pharyngitis/sore throat, dermatitis/itching), average temperature and rainfall, normalizing data, building backpropagation network architecture, determining the dataset to be used for 80% training data and 20% testing data, carrying out the training and data testing process, then simulating the results of the testing.

In this study, the backpropagation architecture used is 5-13-1 that we use 5 (five) parameters as variables that become signals as inputs. They consist of many patients last month (pharyngitis and dermatitis), the average temperature last month, next month's average temperature, last month's rainfall, next month's rainfall, 13 (thirteen) hidden layers, and 1 (one) parameter that produces an output signal variable, that is the number of patients next month (pharyngitis and dermatitis).

From the results of experiments carried out, we have different percentages of precision. Those are the average precision percentage, the best precision percentage, and the worst precision percentage. The results of the precision percentage in the pharyngitis/laryngitis type experiment in November 2020 with an average precision percentage is 68.92%, the best precision is 90.25%, and the worst precision is 47.59%. In December 2020 the average precision percentage is 41.46%, the best precision percentage is 65.55%, and the worst precision percentage is

4.92%. In the type of dermatitis/itching disease in November 2020 the best precision percentage was 98.81%, the average precision percentage was 68.31%, and the worst precision percentage was -21,57%. For December 2020 the average precision percentage is -63.27%, the best precision percentage is 48.37% and the worst precision percentage is -183.85%.

Some of the experiments that got the percentage of precision are not good. It is because the distance of the input data of the number of patients and the rainfall between the previous month and the following month which experienced change drastically. This greatly affects the prediction results of the artificial neural network (ANN) output. This results in a large difference or error value.

## 5 References

- Andriyani, S., dan Sitohang, N. 2018. Implementasi Metode *Backpropagation* Untuk Prediksi Harga Jual Kelapa Sawit Berdasarkan Kualitas Buah. *JURTEKSI Jurnal Teknologi dan Sistem Informas* IV(2): 155-164.
- Ashari, & Muniar, A. Y. (2016). Implementasi Model *Backpropagation* Dan Forward Chaining Dalam Mendiagnosa Penyakit Pencernaan, Vol 6, No.02, Desember 2016
- B. Rifai, "Algoritma Neural Network untuk Prediksi Penyakit Jantung," *J. Techno Nusa Mandiri*, vol. IX, no. 1, pp. 1-9, 2013.
- Basariyadi, A. 2017. Definisi Penyakit dan Jenis Penyakit yang Mengancam Manusia. <https://majalahpendidikan.com/definisi-penyakit-dan-jenis-penyakit-yang-mengancam-manusia/> . 03 Maret 2019 (06:30).
- Bayong Tjasyono, (2004). *Klimatologi*. ITB. Bandung.
- Bustan M. (1997). *Pengantar Epidemiologi*. Rineka Cipta; Jakarta.
- D. WULANDARI, (2011). Peramalan Rata-rata Temperatur Udara Harian Kota Pekanbaru menggunakan Model ARIMA.
- Dewi, Candra., Muslikh, M. (2013). Perbandingan Akurasi *Backpropagation* Neural Network dan ANFIS untuk Memprediksi Cuaca.

- Program Studi Matematika Universitas Brawijaya. Malang
- Komputer Universitas Tanjungpura pontiakan Vol 1, No 1 (2013).
- Ernyasih, (2018). Analisis Hubungan Iklim (Curah Hujan, Kelembaban, Suhu Udara dan Kecepatan Angin) dengan Kasus ISPA di DKI Jakarta Tahun 2011 – 2015, Jurnal Ilmu Kesehatan Masyarakat, Volume 07, Nomor : 03, September 2018, Jakarta.
- F. Suhandi, Krisna. 2009. Prediksi Harga Saham Dengan Pendekatan Artificial Neural Network Menggunakan Algoritma *Backpropagation*, viewed 26 Agustus 2009, <<http://krisnafebrianto.blog.upi.edu/2009/06/27/prediksi-harga-saham-denganmenggunakan-pendekatan-artificialneural-network-menggunakan-algoritmabackpropagation.html>>.
- Fausett, Laurene., 1994, *Fundamentals of Neural Networks Architectures, Algorithms, and Applications*, London: Prentice Hall, Inc.
- H. Wadi, (2020). Jaringan Syaraf Tiruan *Backpropagation* Menggunakan Python GUI : Langkah demi langkah memahami dan mengimplementasikan jaringan syaraf tiruan *Backpropagation* untuk prediksi data penjualan air minum dalam kemasan . TR Publisher. Jakarta.
- Heriyani, F. (2019). Correlation Between Air Temperature and Humidity. *Berkala Kedokteran*, 15(1), 1-6.
- Kartasapoetra, A.G., 1986, *Klimatologi Pengaruh Iklim Terhadap Tanah dan Tanaman*, Jakarta: Bina Aksara.
- Kusumadewi, Sri., 2003, *Artificial Intelligence (Teknik dan Aplikasinya)*, Yogyakarta: Graha Ilmu.
- Muh, A.R. 2017. Peramalan Komoditas Strategis Pertanian Cabai Menggunakan Metode *Backpropagation* Neural Network. *Tugas Akhir*. Fakultas Sistem Informasi FTIF Institut Teknologi Sepuluh Nopember. Surabaya.
- Novi Indah Pradasari ,F.Trias Pontia W,Dedi Triyanto (2013) Aplikasi Jaringan Syaraf Tiruan Untuk Memprediksi Penyakit Saluran Pernafasan Dengan Metode *Backpropagation*, Jurnal Coding Sistem
- Patel, Miss Ankeeta R., Joshi, Maulin M. 2013. Heart diseases diagnosis using Neural Network. EC Departement . India.
- Paramita RM, Mukono J. (2018). Hubungan Kelembapan Udara dan Curah Hujan Dengan Kejadian Demam Berdarah Dengue Di Puskesmas Gunung Anyar 2010-2016. *Indones J Public Heal*. 2018;12(2):202. doi:10.20473/ijph.v12i2.2017.202-212.
- Patel, Miss Ankeeta R., Joshi, Maulin M. (2013). Heart diseases diagnosis using Neural Network. EC Departement. India.
- Psychologymania. 2012. Pengertian Curah Hujan. <https://www.psychologymania.com/2013/05/pengertian-curah-hujan.html>. 11 Maret 2019 (14:02).
- Regariana, C. M. (2005). Atmosfer (Cuaca dan Iklim). Tiga Serangkai, Solo.
- Stasiun Klimatologi Darmaga Bogor. (2012). Analisis Hujan dan Indeks Kekeringan Bulan November 2012 dan Prakiraan Hujan Bulan Januari, Februari dan Maret 2013.
- Surakusumah W. (2011) Adaptasi dan Mitigasi. Bandung.
- Susanti, N. 2014. Penerapan Model Neural Network *Backpropagation* Untuk Prediksi Harga Ayam. *Prosiding SNATIF 2014, Universitas Muria Kudus*: 325-332.
- Suyanto. 2011. Artificial Intelligence, Revisi ed. Bandung: Informatika
- Tjasyono, Bayong., 2004, *Klimatologi*, Bandung: ITB.
- Trimulya, A., Syaifurrahman, dan Setyaningsih, F.A. 2015. Implementasi Jaringan Syaraf Tiruan Metode *Backpropagation* Untuk Memprediksi Harga Saham. *Jurnal Coding Sistem Komputer Untan* 03(2): 66-75.

# PREDICTION OF PATIENTS' ILLNESS BASED ON AVERAGE TEMPERATURE AND RAINFALL IN AZ-ZAINIYAH CLINIC USING BACKPROPAGATION METHOD

## ORIGINALITY REPORT

19%

SIMILARITY INDEX

16%

INTERNET SOURCES

9%

PUBLICATIONS

6%

STUDENT PAPERS

## PRIMARY SOURCES

1	<a href="http://ejournal.unuja.ac.id">ejournal.unuja.ac.id</a> Internet Source	7%
2	<a href="http://media.neliti.com">media.neliti.com</a> Internet Source	1%
3	<a href="http://123dok.com">123dok.com</a> Internet Source	1%
4	<a href="http://qdoc.tips">qdoc.tips</a> Internet Source	1%
5	<a href="http://journal.portalgaruda.org">journal.portalgaruda.org</a> Internet Source	1%
6	I Harlianingtyas, D Hartatie, A Salim. "Modeling of rainfall and fertilization factor of sugarcane productivity in Asembagus sugar factory Situbondo", IOP Conference Series: Earth and Environmental Science, 2018 Publication	1%
7	Rini Sovia, Musli Yanto, Arif Budiman, Liga Mayola, Dio Saputra. "Backpropagation neural	1%

network prediction for cryptocurrency bitcoin prices", Journal of Physics: Conference Series, 2019

Publication

8

teknotugasku.blogspot.com

Internet Source

1 %

9

S.K. Jain, V.P. Singh. "Emerging Techniques for Data Acquisition and Systems Modeling", Elsevier BV, 2003

Publication

1 %

10

Nursida Arif, Edi Nursantosa. "Image Pattern Recognition in Spatial Data using Artificial Neural Network", IOP Conference Series: Earth and Environmental Science, 2021

Publication

<1 %

11

Asma Zuhro, Mangapul Parlindungan Tambunan, Kuswantoro Marko. "Application of vegetation health index (VHI) to identify distribution of agricultural drought in Indramayu Regency, West Java Province", IOP Conference Series: Earth and Environmental Science, 2020

Publication

<1 %

12

Hiya Nalatissifa, Hilman Ferdinandus Pardede. "Customer Decision Prediction Using Deep Neural Network on Telco Customer Churn Data", Jurnal Elektronika dan Telekomunikasi, 2021

<1 %

13 [jeecs.ubhara.ac.id](http://jeecs.ubhara.ac.id) <1 %  
Internet Source

---

14 Erwin Daniel Sitanggang, Tulus, Benny Benyamin Nasution. "Analysis of Satisfaction Level with Servqual method using Artificial Neural Networks", Journal of Physics: Conference Series, 2019 <1 %  
Publication

---

15 [jurnal.polgan.ac.id](http://jurnal.polgan.ac.id) <1 %  
Internet Source

---

16 [hdl.handle.net](http://hdl.handle.net) <1 %  
Internet Source

---

17 [jestec.taylors.edu.my](http://jestec.taylors.edu.my) <1 %  
Internet Source

---

18 Suhartono, Sutikno, Priyo Sidik Sasongko. "Modeling identification of batik motif using the method of back-propagation artificial neural network and template matching algorithm", Applied Mathematical Sciences, 2017 <1 %  
Publication

---

19 Submitted to University of Bradford <1 %  
Student Paper

---

20 [www.scienpress.com](http://www.scienpress.com) <1 %  
Internet Source

---



21 T.J. Bailey. "Preprocessing of industrial process data with outlier detection and correction", Proceedings of the Second International Conference on Intelligent Processing and Manufacturing of Materials IPMM 99 (Cat No 99EX296), 1999  
Publication <1 %

---

22 Submitted to Thames Valley University  
Student Paper <1 %

---

23 [repo.unand.ac.id](http://repo.unand.ac.id)  
Internet Source <1 %

---

24 [medicopublication.com](http://medicopublication.com)  
Internet Source <1 %

---

25 Ike Fitriyaningsih, Anthon R. Tampubolon, Harry L. Lumbanraja, Grace E. Pasaribu, Pita S.A. Sitorus. "Implementation of Artificial Neural Network to Predict S&P 500 Stock Closing Price", Journal of Physics: Conference Series, 2019  
Publication <1 %

---

26 [mafiadoc.com](http://mafiadoc.com)  
Internet Source <1 %

---

27 Jimenez-Vargas, A.. "Means of extreme points and F-spaces", Journal of Mathematical Analysis and Applications, 20030715  
Publication <1 %

---

28

Hermawan Syahputra, Zulfahmi Indra, Didi Febrian, Dhea Putri Adriani. "Leaf feature extraction using glcm, moment invariant and shape morphology for indonesian medicinal plants recognition", Journal of Physics: Conference Series, 2019

Publication

&lt;1 %

29

K. G. Margaritis, D. J. Evans. "On systolic general system solution for optimal artificial neural network training", International Journal of Computer Mathematics, 1994

Publication

&lt;1 %

30

M F Syahputra, S M Hardi, A Prasetyo. "Recognition of Hand Movement for Training Motor Skill of Children With Autism Spectrum Disorder (ASD) Using Myo Gestures Control Armband and Artificial Neural Network", Journal of Physics: Conference Series, 2021

Publication

&lt;1 %

31

[adoc.pub](http://adoc.pub)

Internet Source

&lt;1 %

32

[www.climatechangeconnection.org](http://www.climatechangeconnection.org)

Internet Source

&lt;1 %

33

[www.ijain.org](http://www.ijain.org)

Internet Source

&lt;1 %

34

I Budiman, A Mubarak, S Kapita, S Do. Abdullah, M Salmin. "Implementation of

&lt;1 %

# Backpropagation Artificial Network Methods for Early Children's Intelligence Prediction", E3S Web of Conferences, 2021

Publication

---

---

Exclude quotes      On

Exclude matches      Off

Exclude bibliography      On

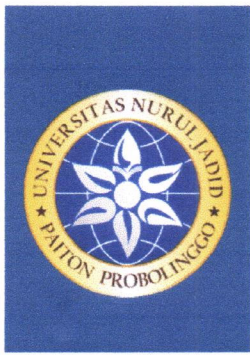

YAYASAN NURUL JADIDPAITON

**LEMBAGA PENERBITAN, PENELITIAN &  
PENGABDIAN KEPADA MASYARAKAT  
UNIVERSITAS NURUL JADID  
PROBOLINGGO JAWA TIMUR**

PP. Nurul Jadid  
Karanganyar Paiton  
Probolinggo 67291  
☎0888-3077-077  
lp3m@unuja.ac.id

**SURAT KETERANGAN**

Nomor : NJ-T06/0543/A1/01.2022

Lembaga Penerbitan, Penelitian, dan Pengabdian Masyarakat (LP3M) Universitas Nurul Jadid Probolinggo menerangkan bahwa artikel/karya tulis dengan identitas berikut ini:

Judul : *Prediction Of Patiens' Illnesss on Average Temperature and Rainfall In Az-Zainiyah Clinic Using Backpropagation Method*  
Penulis : M. Noer Fadli Hidayat, M. Kom  
Identitas : TRILOGI - Volume 2 No 3 September - Desember Tahun 2021.  
No. Pemeriksaan : 1738965729

Telah selesai dilakukan *similarity check* dengan menggunakan perangkat lunak **Turnitin** pada 09 Januari 2022 dengan hasil sebagai berikut:

Tingkat kesamaan diseluruh artikel (*Similarity Index*) adalah 19 % dengan publikasi yang telah diterbitkan oleh penulis pada TRILOGI - Volume 2 No 3 September - Desember Tahun 2021 (<https://ejournal.unuja.ac.id/index.php/trilogi/article/view/3169/pdf>)

Demikian Surat Keterangan ini dibuat untuk digunakan sebagaimana mestinya.

Probolinggo, 09 Januari 2022

Kepala LP3M,



**ACHMAD EAWAID, M.A., M.A.**

NIDN. 2123098702